

4100 SERIES



Series 4100, is a high performance, permanent magnet brush servo motor for use in various industrial direct drive or geared servo systems

- Rugged industrial construction
- Continuous torque ratings up to 48 lb.-in. —with speeds up to 3500 RPM
- Peak torque ratings up to 240 lb.-in.
- IP65 Sealing available
- Superior low speed performance
- Numerous custom options available
- CE / UL



Performance Benefits

CMC Torque Systems specializes in the design of high performance brush servo motors that provide efficiency, flexibility of application, and a long and trouble-free service life. Our TORQUEMASTER® 4100 series is no exception.

With fast response, accurate control and high torque-to-inertia ratios, you can count on the TORQUEMASTER 4100 Series of brush servo motors to provide smooth operation throughout a full speed range. The 4100 Series delivers smooth and superior low speed performance, and maximum power ratings with low thermal resistance for high speed performance. In addition, with maximum torque in a smaller package, you can count on better pricing for a better overall value.

When integrated with high performance brush amplifiers, TORQUEMASTER 4100 Series brush servo motors provide effective and highly efficient motion control solutions for a wide range of applications—including factory automation, packaging, robotics, machine tools, medical instrumentation and more.

Design Features

TORQUEMASTER 4100 Series brush servo motors are rated from 12 lb.-in. to 48 lb.-in. with speeds and torque stability up to 3500 RPM. They utilize the latest in high performance permanent magnet technology, and are available in seven standard windings (as well as custom windings) to meet your most demanding applications.

Each brush servo motor in the TORQUEMASTER 4100 Series is ruggedly designed and manufactured for reliable performance.

Motors can be customized to fit your exact application with tachometers, encoders, brakes and other options.



BRUSH SERVO MOTOR CHARACTERISTICS

SYMBOL		UNITS	4101	4102	4104	4106
T _C	Cont. Torque	Lb-In	12	24	36	48
T _P	Peak Torque	Lb-In	60	120	180	240
T _F	Static Friction	Lb-In	1.1	1.1	1.1	1.1
F _i	Viscous Friction	Lb-In/KRPM	.30	.40	.70	.90
T _R	Cogging Torque	Lb-In	.63	.63	.63	.63
J _M	Inertia	Lb-In-sec ²	.0078	.011	.018	.024
R _{TH}	Thermal Res	Deg C/watt	1.7	1.2	1.1	1.0
T _{TH}	Thermal Time	Minute	52	55	58	60
t _m	Mech Time	Millisec	20	10.5	7.6	6.9
t _e	Elect Time	Millisec	4.8	5.2	5.4	5.7
F _C	Commutation (41Bar)	Factor	575	956	1438	2011
Wt	Weight	Lbs	12	15	20	25

Note: All values at 25°C Ambient.

WINDING

B	K _T	Torq. Sens.	Lb-In/Amp	.76	1.37	2.40	3.47
	R _A	Arm. Resis.	Ohms	.150	.20	.30	.38
	K _V	Back E.M.F	Volts/KRPM	9	16	28	41
	F _C /K _T	P _b	Watts	757	689	599	580
C	K _T	Torq. Sens.	Lb-In/Amp	1.14	2.06	3.60	5.20
	R _A	Arm. Resis.	Ohms	.34	.43	.62	.85
	K _V	Back E.M.F	Volts/KRPM	13	24	42	61.5
	F _C /K _T	P _b	Watts	504	464	399	387
D	K _T	Torq. Sens.	Lb-In/Amp	1.52	2.75	4.80	6.94
	R _A	Arm. Resis.	Ohms	0.6	.78	1.15	1.55
	K _V	Back E.M.F	Volts/KRPM	18	33	57	82.1
	F _C /K _T	P _b	Watts	378	348	300	290
E	K _T	Torq. Sens.	Lb-In/Amp	1.90	3.44	6.01	8.68
	R _A	Arm. Resis.	Ohms	.95	1.24	1.82	2.40
	K _V	Back E.M.F	Volts/KRPM	22	41	71	103
	F _C /K _T	P _b	Watts	303	278	239	231
F	K _T	Torq. Sens.	Lb-In/Amp	2.28	4.13	7.21	10.42
	R _A	Arm. Resis.	Ohms	1.32	1.68	2.46	3.24
	K _V	Back E.M.F	Volts/RPM	27	49	85	123
	F _C /K _T	P _b	Watts	252	232	199	193
G	K _T	Torq. Sens.	Lb-In/Amp	2.66	4.78	8.41	12.15
	R _A	Arm. Resis.	Ohms	1.89	2.47	3.62	4.77
	K _V	Back E.M.F	Volts/KRPM	31	57	99	144
	F _C /K _T	P _b	Watts	216	226	171	166
H	K _T	Torq. Sens.	Lb-In/Amp	3.04	5.50	9.61	13.9
	R _A	Arm. Resis.	Ohms	2.41	3.15	4.62	6.09
	K _V	Back E.M.F	Volts/KRPM	36	65	114	164
	F _C /K _T	P _b	Watts	189	172	150	145

For custom designs please consult factory.

All specifications subject to change without notice.

MECHANICAL SPECIFICATIONS*

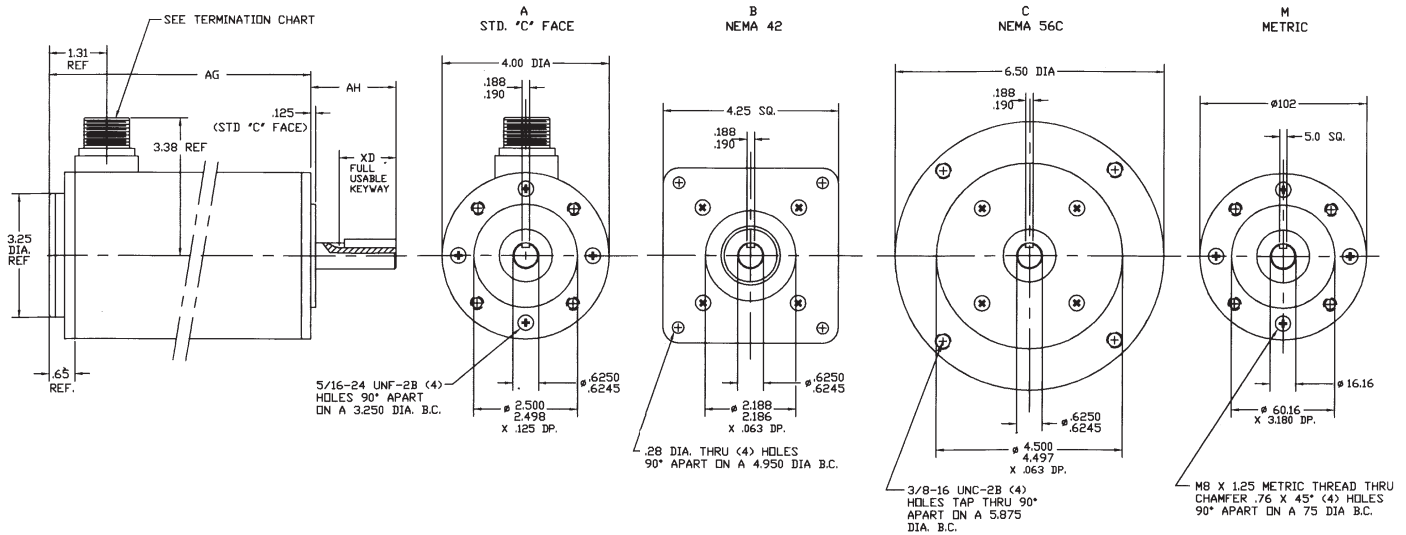

DIMENSION CHART* (Motor Length - AG in inches)

MOTOR	A	B	C	M
	STD C Face	NEMA 42	NEMA 56C	Metric
4101	6.85	7.19	7.19	174
4102	7.85	8.19	8.19	199.4
4104	9.85	10.19	10.19	250.2
4106	11.85	12.19	12.19	301

F.E.P.	AH	XD
	Shaft Ext.	Key Way
STD. "C"	2.06	1.38
NEMA 42	1.38	.80
NEMA 56C	2.06	1.38
METRIC	45	30

*All specifications are for reference only. Please consult the factory for certified dimension drawings.

TORQUE PERFORMANCE CURVES

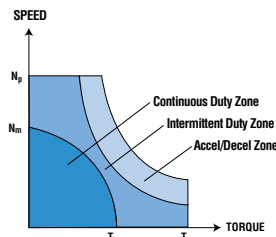

NOTE: Continuous torque specifications obtained with motor mounted to an 8.5"x12"x0.5" aluminum plate at 25 °C ambient. Typical values are within $\pm 10\%$ of rating.

STANDARD WINDING SPEED/TORQUE CURVE DATA FOR SIZING A SERVO MOTOR

- N_m = Maximum speed, continuous operation
- N_p = Peak speed, acceleration/deceleration and intermittent duty
- T_{cs} = Continuous stall torque
- T_p = Peak torque

All specifications subject to change without notice.

TORQUE PERFORMANCE CURVES

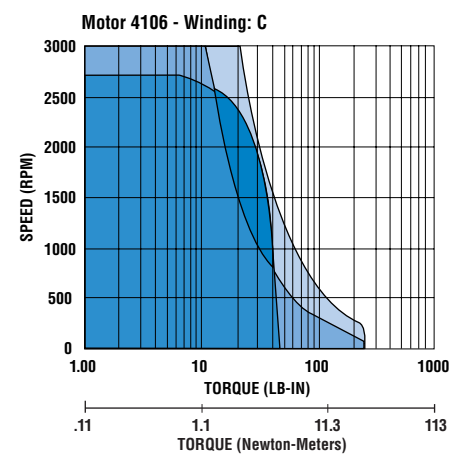
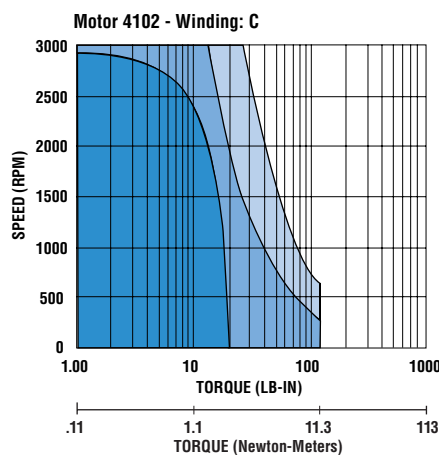
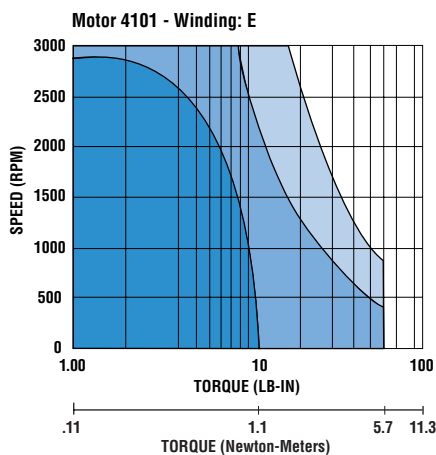

TORQUE SPEED CURVES OF OTHER WINDINGS AVAILABLE, CONSULT FACTORY.

BRUSH SERVO MOTORS

4100 SERIES

VOLTAGE EQUATION FOR MOTORS

$$\text{Volts} = \frac{K_T \times \text{RPM}}{1,350} + \frac{T \times R_A}{K_T} + V_B$$

Where:

- K_T = torque constant, oz.-in. per amp
- T = load torque plus motor friction torque-oz.-in.
- R_A = armature resistance + brush resistance
- V_B = brush voltage drop = 2 volts

Note: For armature resistance at maximum temperature rating, multiply catalog value of R by 1.5

MOTOR TORQUE RATING VS. SPEED

$$T_R = .94K_T \left[\frac{130 \cdot \text{RPM} \times T_F - \text{RPM}^2 \times F_i}{1,350 \cdot 1,350,000} \right]^{1/2} - T_F - \left[\frac{\text{RPM} \times F_i}{1000} \right]$$

Where:

- T_R = rated torque (25°C ambient)-oz.-in.
- K_T = torque sensitivity-oz.-in./amp
- R_A = armature resistance
- RPM = revolutions per minute
- T_F = static friction torque-oz.-in.
- F_i = viscous friction-oz.-in.
- R_{TH} = thermal resistance

To Find: Higher Torque Rating for Intermittent Duty

$$\text{Let } A = \frac{\text{total cycle time in seconds}}{\text{thermal time constant of motors in seconds}}$$

$$\text{Let } B = \frac{\text{"on" time in seconds per cycle}}{\text{thermal time constant of motor in seconds}}$$

then with T_R = Rated torque for 100% duty
and T_{MAX} = Rated torque for intermittent duty

$$T_{MAX} = T_R \times \left[\frac{1 - e^{-A}}{1 - e^{-B}} \right]^{1/2}$$

Customize The 4100 Series To Your Exact Requirements

To satisfy various applications with cost-effective solutions, 4100 Series motors are readily available with a wide range of standard capabilities. Final designs are often the result of cooperative efforts between the customer's engineering department and CMC. For assistance, call your local CMC distributor or CMC direct. We look forward to meeting your custom requirements.

TORQUEMASTER®

ORDERING INFORMATION (For Standard Options)

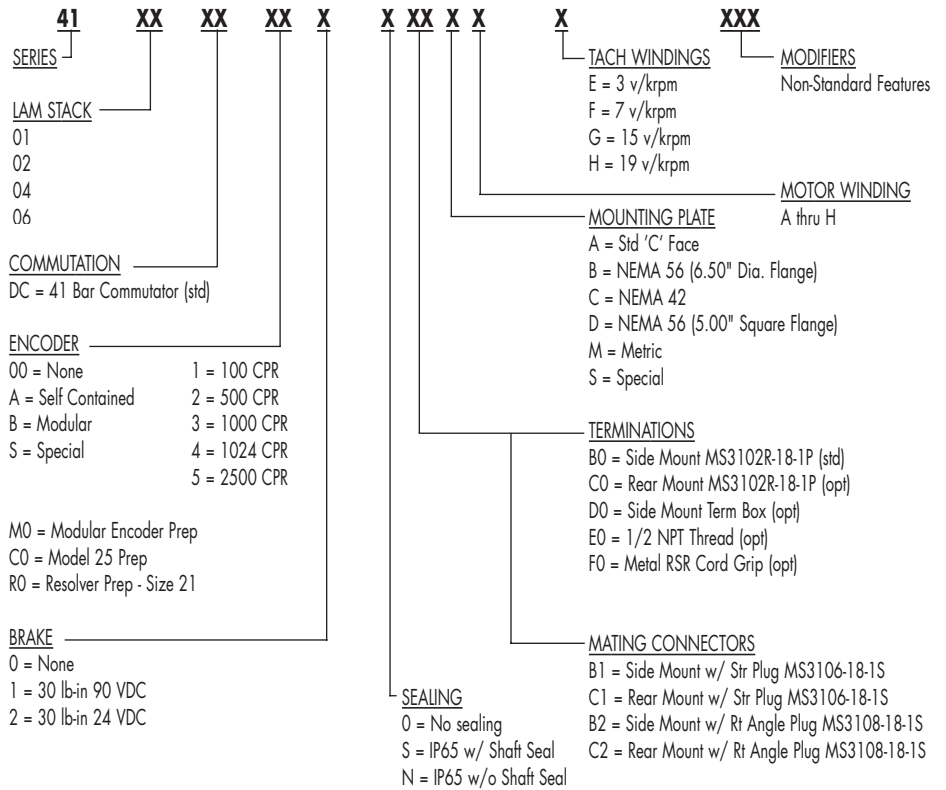

INTEGRAL DC TACHOMETER SPECIFICATIONS

Winding Options	E	F	G	H
Output volts / 1000 RPM ± 10%	3	7	15	19
Resistance (ohms) ± 15%	45	100	450	390
Maximum ripple*	± 1.5%	± 1.5%	± 1.5%	± 2.0%
Voltage change w/temp. per deg C	.016%	.016%	.016%	.016%
Rotor inertia (Oz-In Sec 2)	0.001	0.001	0.001	0.001

*With a 1.5 kHz filter and 10K ohm load impedance for E and F windings, 40K ohm load impedance for G and H windings

TERMINATION CHART MS3102R-20-29P

Connection code for CCW rotation			
Motor/Tach/Mod. Encoder/Brake			
PIN	Function	PIN	Function
A	Motor+	K	B Output
B	Motor-	L	\bar{B} Output
C	Ground	M	M Output
D	Tach+	N	\bar{M} Output
E	Tach-	P	+5 VDC
F	Thermostat	R	Common
G	Thermostat	S	Case Gnd.
H	A Output	T	Brake
J	\bar{A} Output	U	Brake

TERMINATION CHART MS3102R-18-1P

Connection code for CCW rotation			
Motor/Tach/Brake			
PIN	Function	PIN	Function
A	Motor+	F	Thermostat
B	Motor-	G	Thermostat
C	Ground	H	Brake
D	Tach+	J	Brake
E	Tach-		



6 Enterprise Road, Billerica, MA 01821-5734
Call: 800-669-5112 or 978-667-5100
Fax: 888-295-5550 or 978-667-4989

Visit Us: www.torquesystems.com

